

1955 Chevrolet LED Turn / Back-Up Installation

Installation Instructions

1. **Disconnect Battery.** **Do not skip this step.** Also, do not try to “test” the LED array by connecting the leads directly to your battery. Permanent damage will occur to the LED array if you fail to heed these steps.
2. These instructions only cover the amber turn signal / back-up light installation. See other instructions for the stop lamp led array. These instructions assume Technostalgia’s stop lamp LED array will also be installed. If this is not the case, please contact Technostalgia for an alternate wiring diagram. These instructions also assume that your car has a GM back-up light harness and appropriate switch. If not, the amber turn signals will work without the back-up light function connected.
3. Remove taillight bezel, upper and lower lens.
4. Remove the back-up light bulb.
5. Disconnect the harness from the taillight by turning the plastic connector clockwise.
6. Drill a 5/32 hole in the taillight housing. See attached photos for location. This hole is only for the harness to pass through. The exact location is not critical.
7. Pass the supplied LED harness through the 5/32” hole in the taillight housing.
8. Install the turn / back-up LED array using the supplied hardware. Refer to the attached photos. Connect the LED harness to the LED array. Note connector orientation in the photos.
9. **Driver’s side.** Following the attached wiring diagram and using the supplied connectors, connect the supplied harnesses to the original GM harness. To use the connector: put both (or three in some cases) wires in a separate hole, unstripped. Holding the wires as far in as possible, squeeze the connector with pliers. Some “goo” may come out of the connector. This “goo” ensures a watertight connection. Repeat by connecting the pink wire on your car to the red wire on the supplied harness.
10. As shown on the wiring diagram, it is necessary to run a wire (supplied) from the trunk area to under the dash
11. Under the dash there are two orange wires going into the stop lamp switch and one white wire exiting the switch. Connect as shown in the diagram.
12. After all of the connections are made, reassemble both taillights. Remember to connect all four (4) ground wires. See photos for details.
13. Reconnect the battery.
14. Test the STOP, turn, back-up and taillight functions.
15. Enjoy!

Technostalgia

1889 E Telegraph Hill Rd

Madison Indiana 47250

812-265-0062

e-mail: tsondles@seidata.com

1955 Connection Diagram

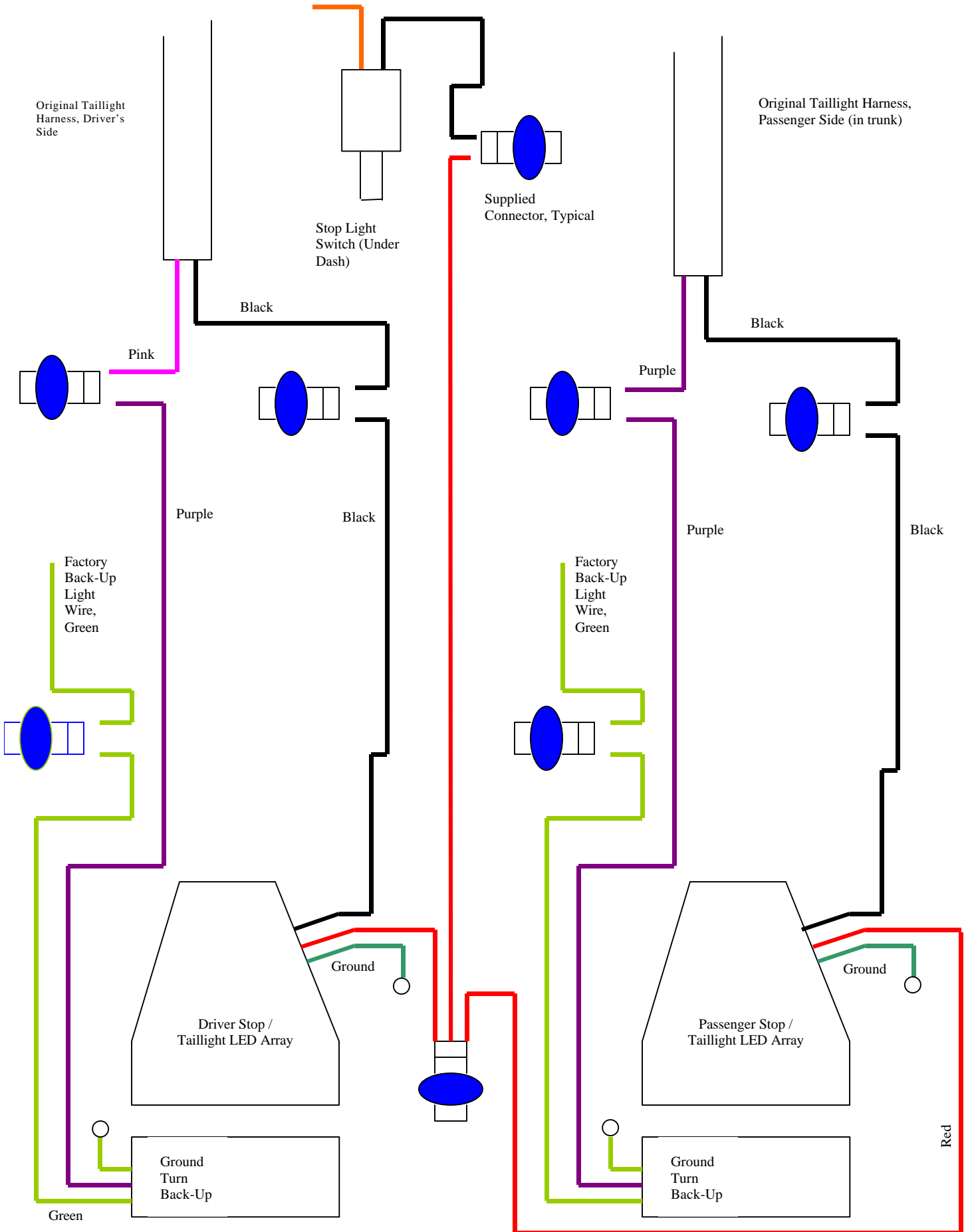

1955 Photo Reference

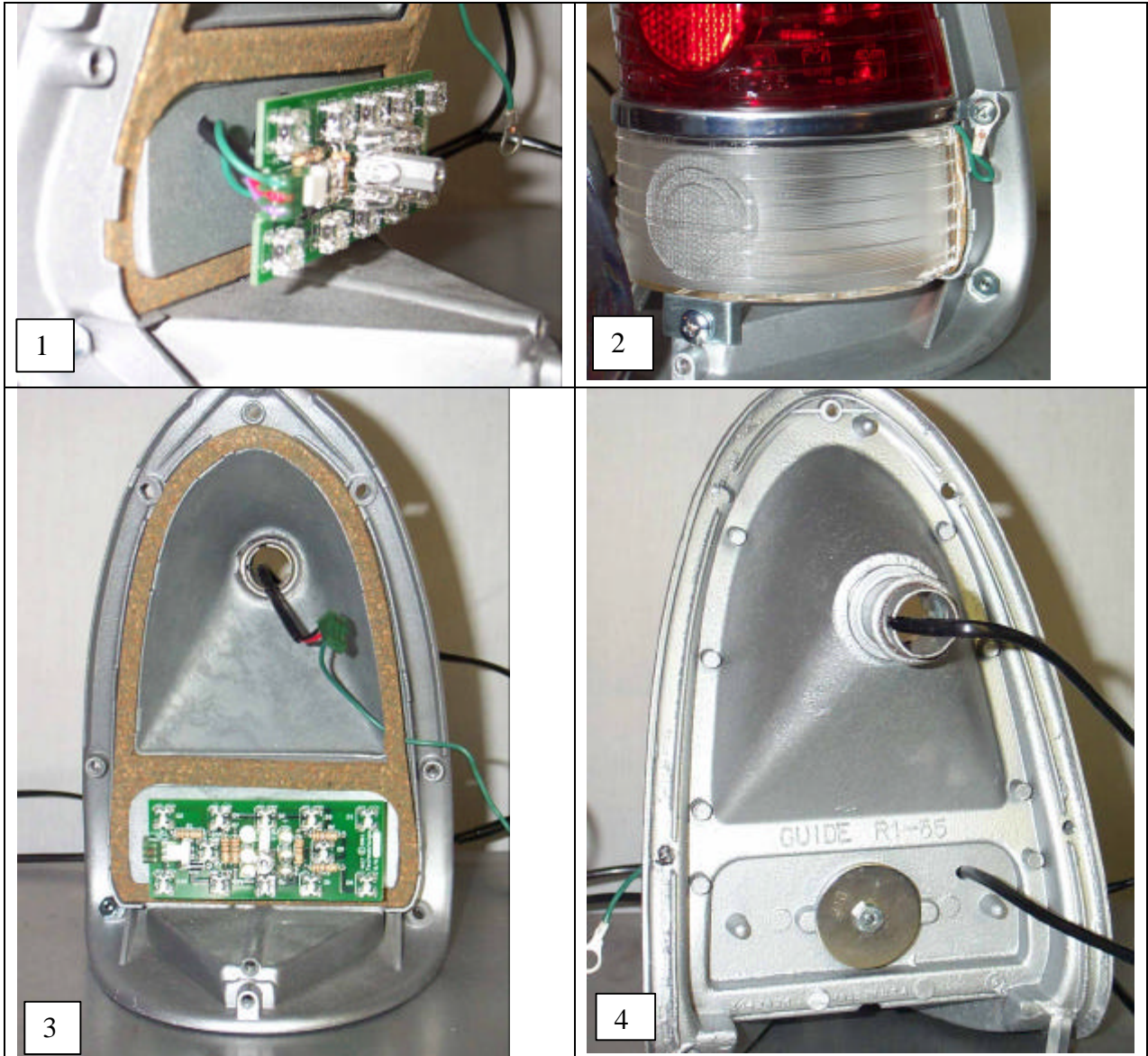

1. Reference the position of the 5/32" hole for the wiring harness. Note attaching hardware and connector orientation.
2. Note location of the ground wire for the Stop LED array. The ground wire for the turn LED array is not shown. It goes to the hex stud that holds the turn LED array.
3. General reference photo.
4. Location of the 5/32" hole for the wiring harness. Note attaching hardware.