





## Installation Instructions

1. **Disconnect Battery.** **Do not skip this step.** Also, do not try to “test” the LED array by connecting the leads directly to your battery. Permanent damage will occur to the LED array if you fail to heed these steps.
2. Remove Taillight housings from car.
3. Disassemble taillight housings.
4. Remove light bulb.
5. For 30-32 housing, the tail / stop light divider must be removed. A 11/32” drill works well for this.
6. Attach the plastic connector on the supplied harness to the LED array. Photo 1
7. Attach the green ground wire to one of the studs on the back of the LED array. Photo 2
8. Pass the free end of the harness through the taillight housing. Photo 4
9. **An extra set of hands is helpful for this step.** Align the LED array, taillight housing, and stanchion while installing the supplied stainless steel screws and lockwashers.
10. If you have a ‘30-’32, you must use the supplied screws to attach the bezel to the new LED bracket.
11. Reassemble the rest of the taillight.

12. **Wiring.** Using the supplied connectors, connect the wire from the taillight circuit to the black wire on the supplied harness. To use the connector:

### QUICK & EASY!

- ① Strip wire 1/2" 
- ② Twist 
- ③ Insert 
- ④ Hand tighten 

13. Repeat by connecting the wire from the brake light circuit on your car to the red wire on the supplied harness. If your car is fiberglass, the housing must be grounded.
14. Repeat for the other side.
15. Reconnect the battery.
16. Test both STOP and taillight functions.
17. Enjoy!

### *Technostalgia*

1889 E Telegraph Hill Rd

Madison Indiana 47250

812-265-0062

e-mail: [info@cool-leds.com](mailto:info@cool-leds.com)

[WWW.Cool-leds.com](http://WWW.Cool-leds.com)

*Photo Reference*

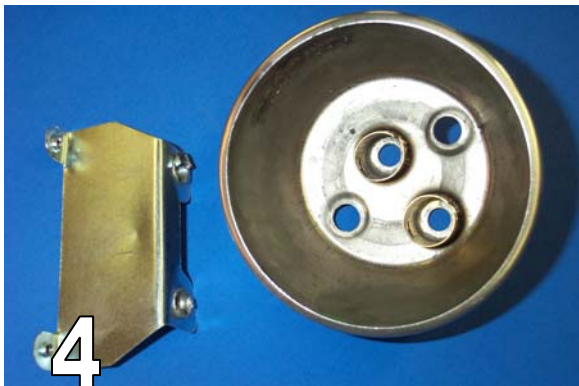
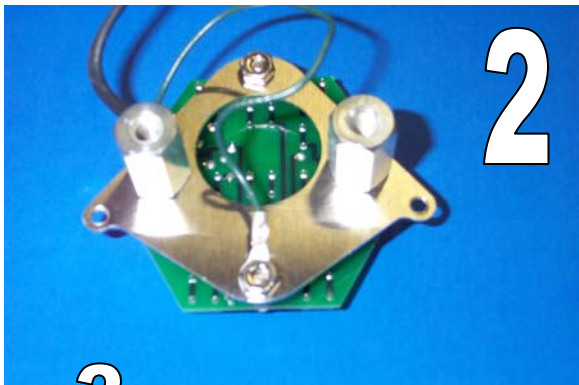
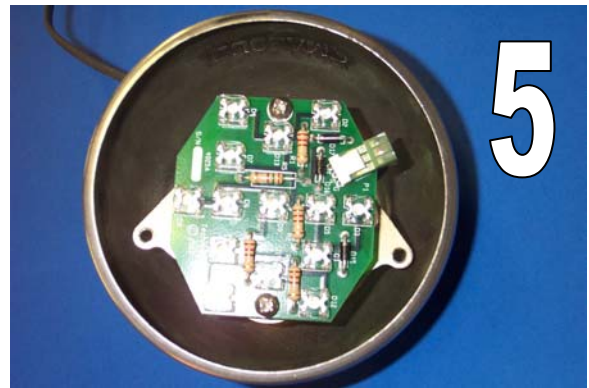
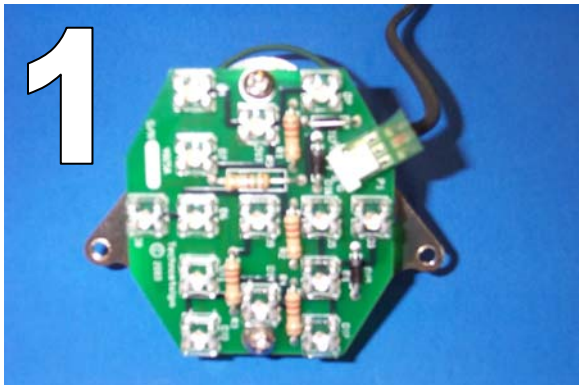



### Photo Explanation

1. Plug the green harness connector into the receptacle on the LED array.
2. Connect green ground wire to one of the studs on the back of the LED array.
3. The divider wall will need to be removed in the '30-'32 taillight housings.
4. Pass the supplied harness wire through the top hole.
5. LED array positioned in the taillight housing.
6. For '30-'32 housings, the bezel will attach to the supplied stainless steel bracket using the supplied screws.
7. Installing the bezel screws.
8. Parts included in the Technostalgia kit.

### Technical Notes

1. For cars using the stock license plate location, **the LED will not illuminate the license plate.** We suggest using the commercially available LED license plate bolts.
2. Turn Signal Flashers: If your car has a conventional bulb in the front parking light, your existing flasher should work. If you have an LED or no front parking light, you will need an electronic flasher. We have these available.
3. After installation of this kit, your taillight will no longer have a

divided tail / stop light. The tail and stop lights will be in the entire lens area.

4. Normal operation of the LED array has two LEDs lit at full brightness and 12 leds at reduced brightness for the tail function. All 14 LEDs are lit at full brightness for both the stop and turn function.

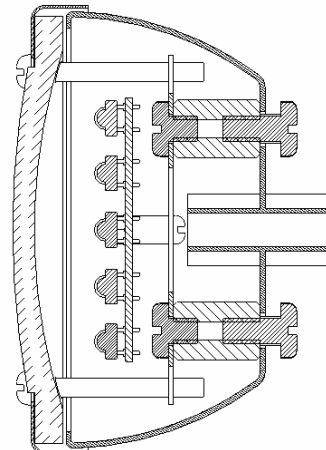

*Top view cross-section showing completed assembly. '30-'32 housing shown. Stanchion not depicted.*

### 35-36 Ford Installation

If you are installing this LED kit in a '35 or '36 Ford, you must use the auxiliary hardware supplied in a separate bag.

1. Disassemble the LED array from the stainless bracket.
2. Remove the hex spacers from the stainless bracket.
3. Attach the stainless bracket to the taillight housing and stanchion using the supplied fine thread screws and plastic spacers.
4. Re-attach the LED array.

### **Technostalgia**

*1889 E Telegraph Hill Rd*

*Madison Indiana 47250*

*812-265-0062*

*e-mail: [info@cool-leds.com](mailto:info@cool-leds.com)*

*[WWW.Cool-leds.com](http://WWW.Cool-leds.com)*